

GREY 9

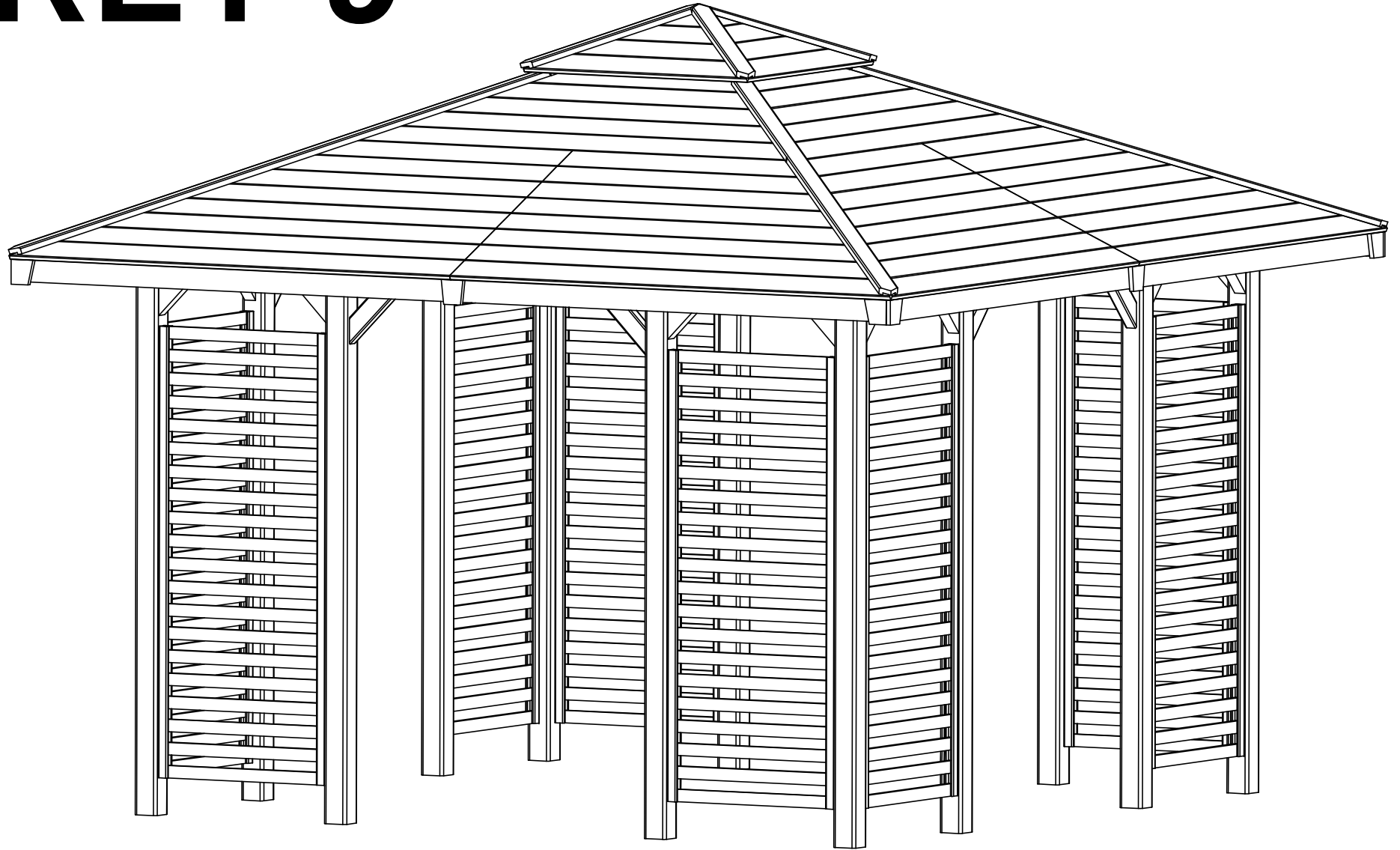

1

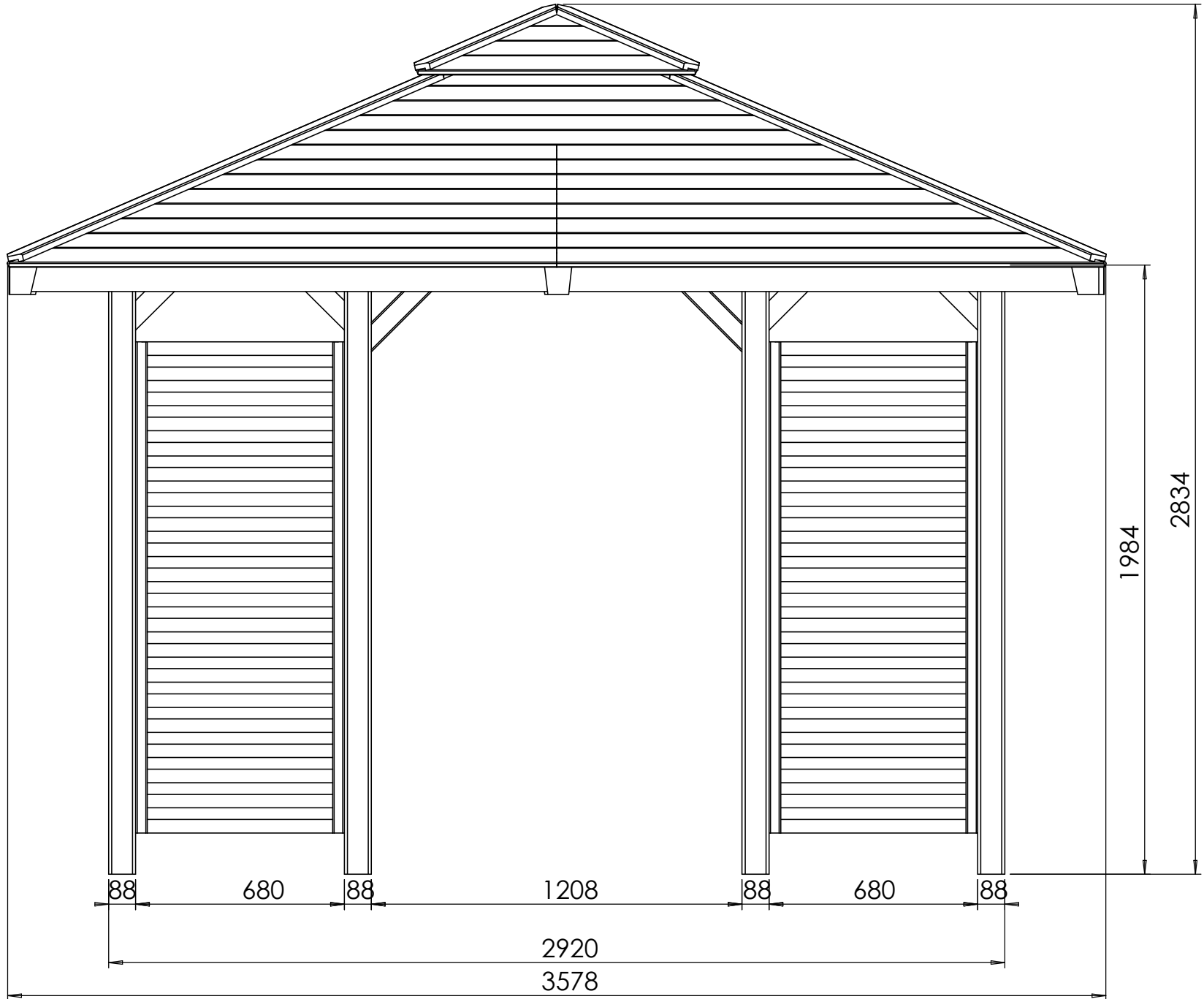

| | | | |
|------|-----|-------------|--|
| A | 8 | 44x680x1600 | |
| B | 12 | 88x88x1984 | |
| Ca | 16 | 44x68x300 | |
| C | 8 | 44x68x400 | |
| D | 2 | 88x88x856 | |
| Da | 2 | 88x88x856 | |
| E | 4 | 88x88x1384 | |
| F | 4 | 88x88x856 | |
| G | 4 | 44x68x400 | |
| H | 4 | 44x68x1445 | |
| Ha | 4 | 44x68x1314 | |
| I | 4 | 44x68x1899 | |
| K | 4 | 44x68x1066 | |
| O | 4 | 44x68x1066 | |
| J | 8 | 18x88x1759 | |
| L,La | 4+8 | 18x88x888 | |
| N+Na | 4 | 28x68x2060 | |
| M | 4 | 490x900 | |
| P | 4 | 28x68x680 | |

R 533x533

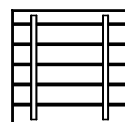

| | | |
|----|---|-------------|
| R1 | 4 | 16x120x237 |
| R2 | 4 | 16x120x459 |
| R3 | 4 | 16x120x681 |
| R4 | 4 | 16x120x903 |
| R5 | 4 | 16x120x1125 |
| R6 | 4 | 16x120x1347 |
| R7 | 4 | 16x120x1569 |
| R8 | 4 | 16x120x1792 |
| T1 | 8 | 16x120x1007 |
| T1 | 8 | 16x120x1118 |
| T3 | 8 | 16x120x1229 |
| T4 | 8 | 16x120x1340 |
| T5 | 8 | 16x120x1451 |
| T6 | 8 | 16x120x1562 |
| T7 | 8 | 16x120x1673 |
| T8 | 8 | 16x120x1784 |

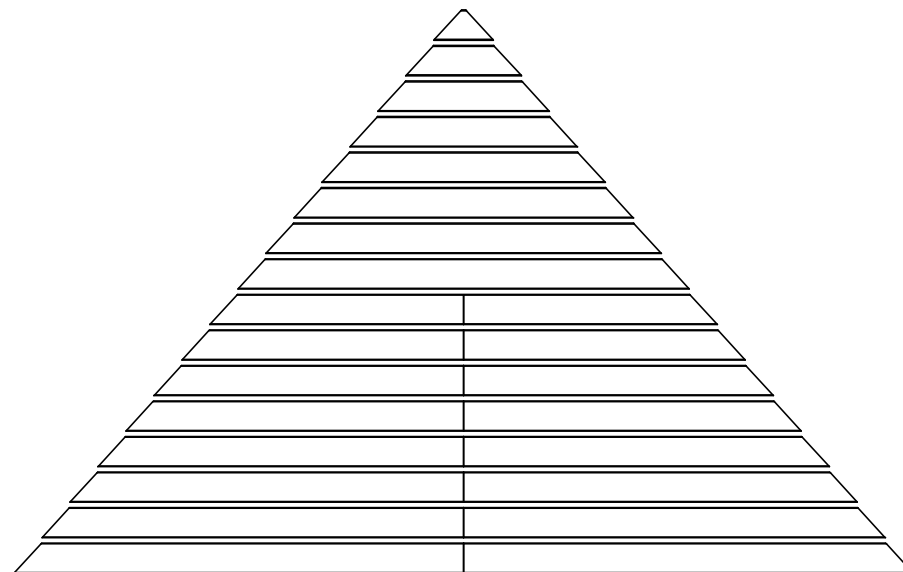

| | | | |
|-----|-----|--------|--|
| Zs | 8 | 6x80 | |
| Zs | 8+8 | M6+M6 | |
| Sw | 24 | 3,5x40 | |
| Kw | 96 | 5x90 | |
| Ww | 48 | 4x70 | |
| Cw | 40 | 6x120 | |
| Pw | 64 | 4x60 | |
| Tx | 12 | 8x60 | |
| Gp | 524 | | |
| CAP | 8 | M6 | |

Px 1

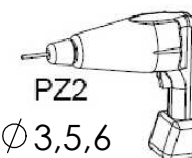
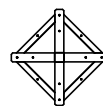

Ø 3,5,6

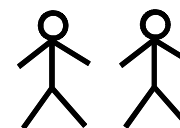
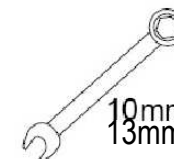

Attention : For wooden elements natural effects of drying process are deformations . Depending on the air humidity measures can be different to the ones described up to 0,3 % of thickness and 5 % of width .
 Achtung: Durch wechselnde Witterungseinflüsse kann das Holz quellen oder schrumpfen. Je nach Feuchtigkeit können geringfügige Massabweichungen auftreten: bis 0,3% bei der Länge und bis 5% bei der Stärke.
 Uwaga: Elementy drewniane ulegają odkształceniu w procesie wysychania. W zależności od wilgotności powietrza wymiary mogą się różnić od podanych na długości ~ 0,3% na grubości i szerokości 5%.

3

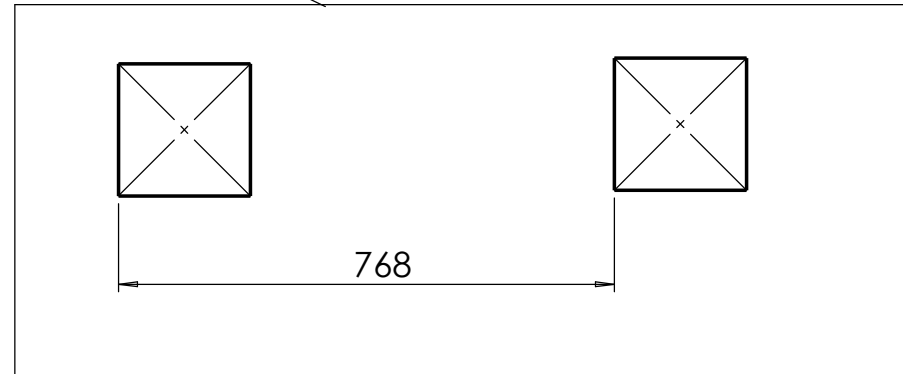
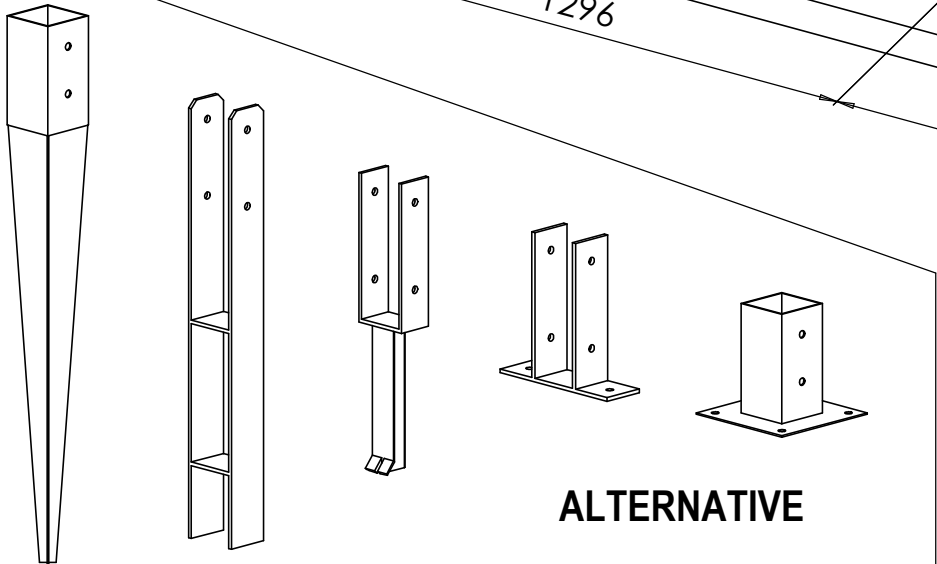
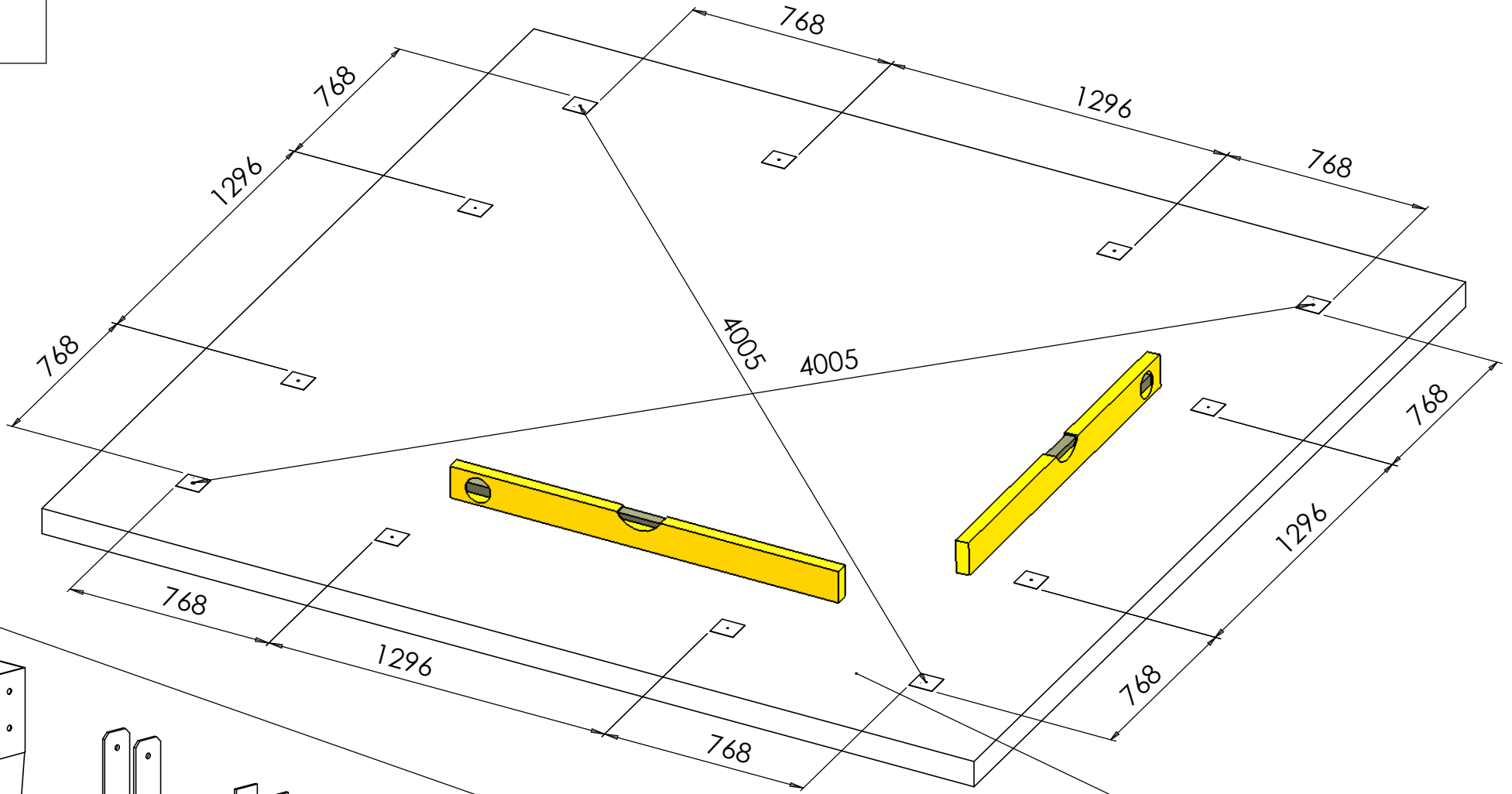

4

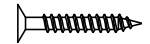
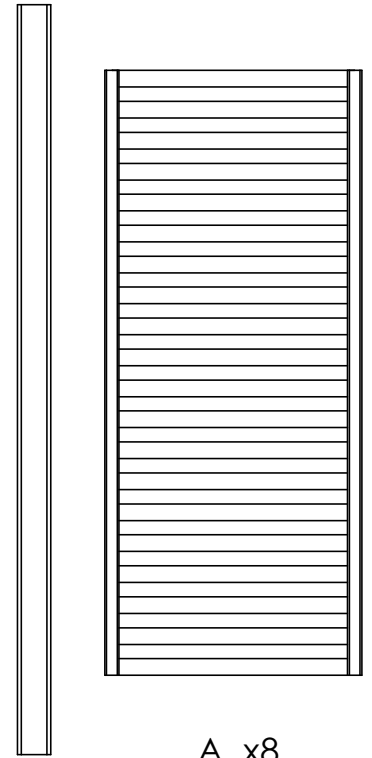
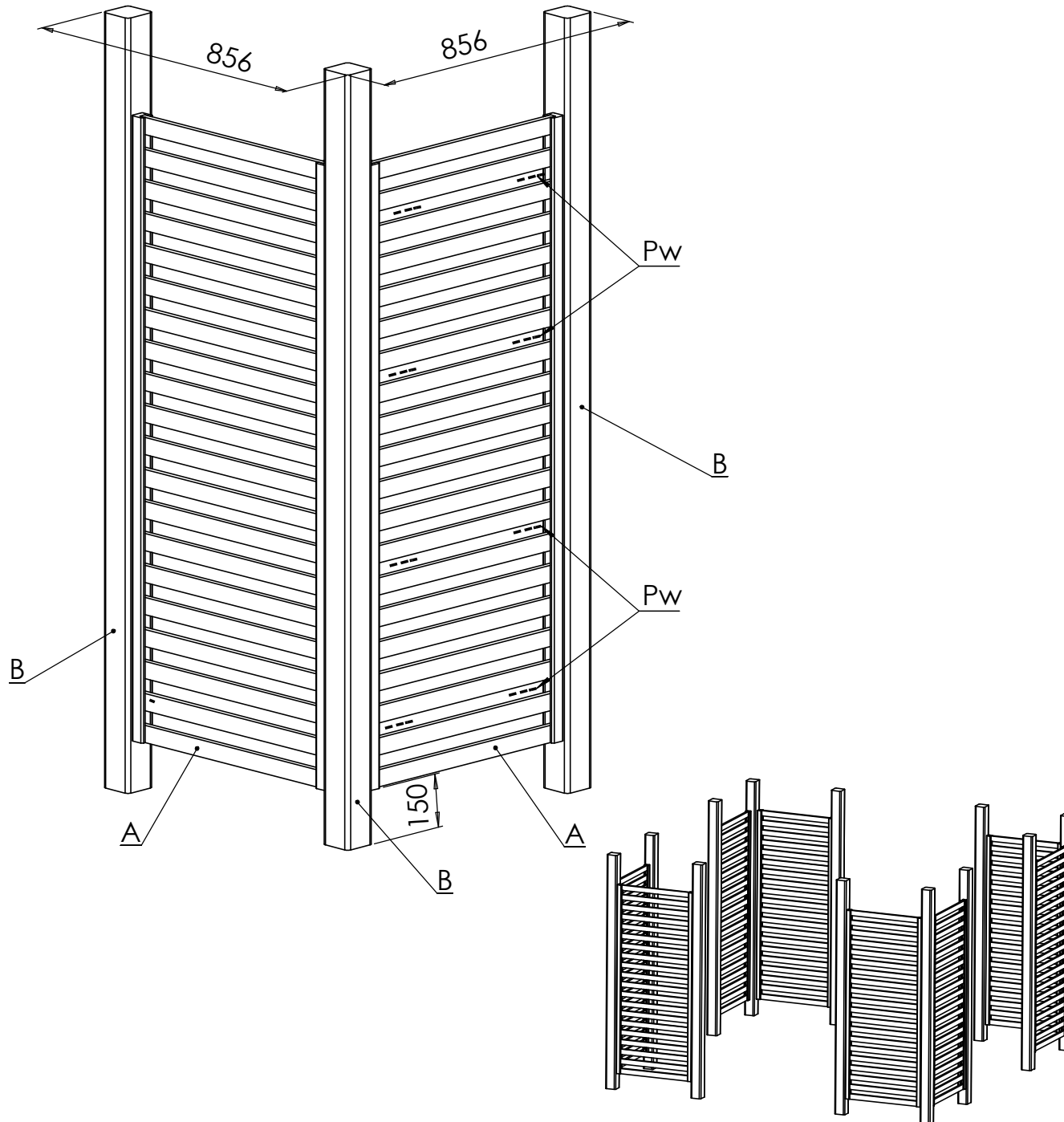

Pw 4 x 60 x 64

5

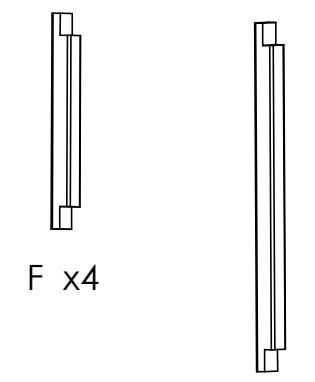
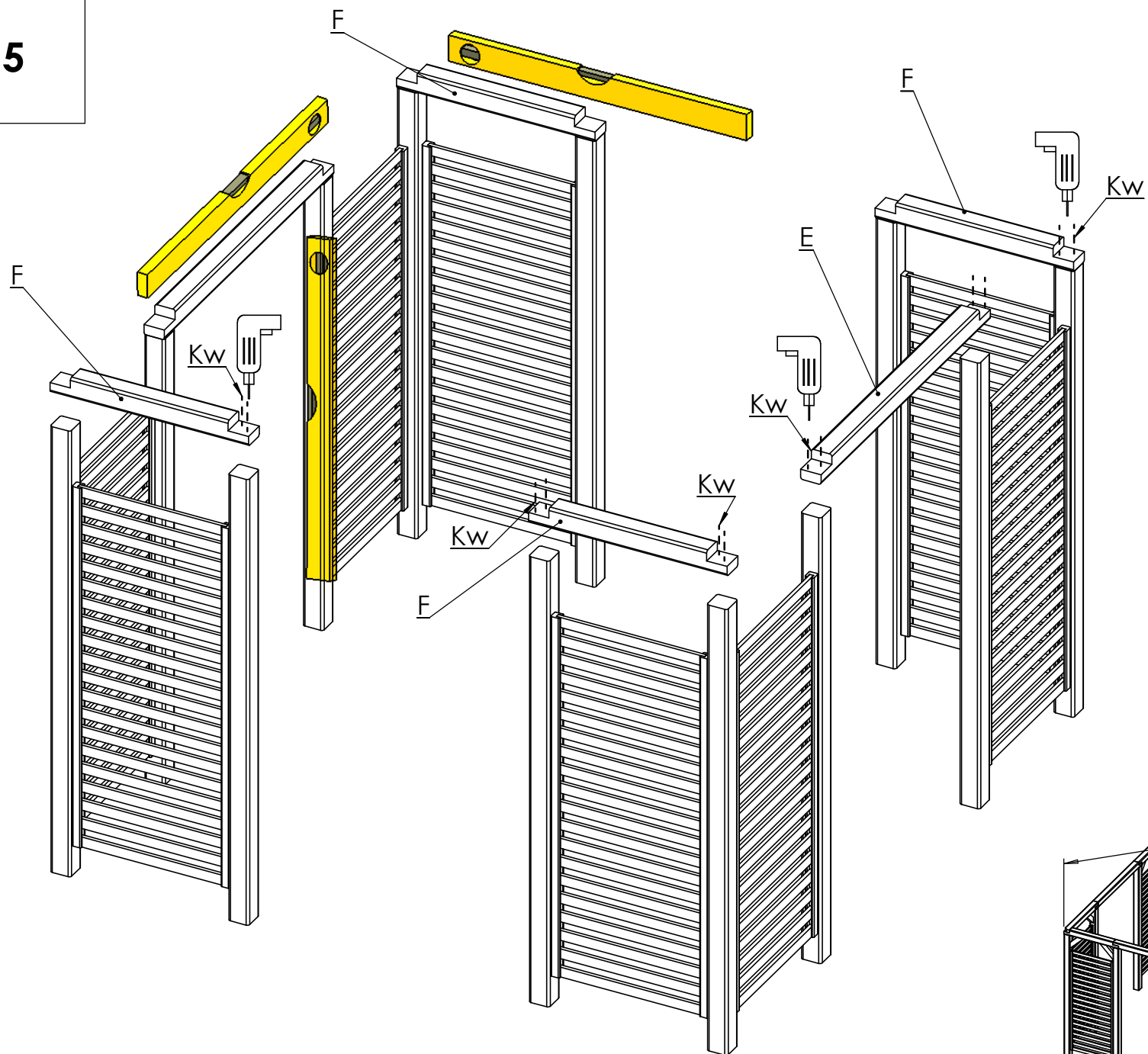

F x4

E x2

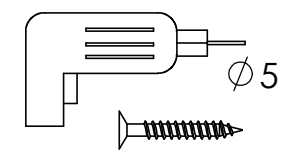

Kw 5x90 x24

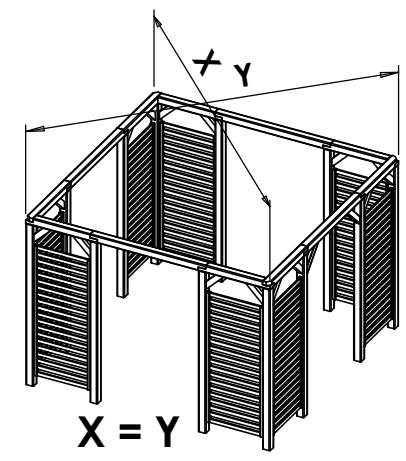

6

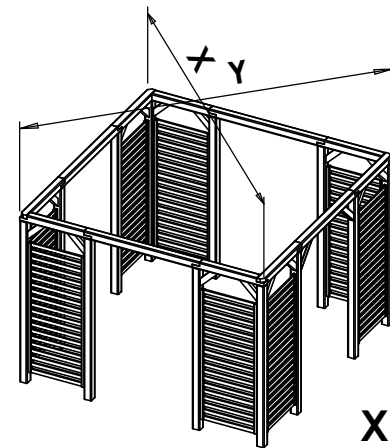
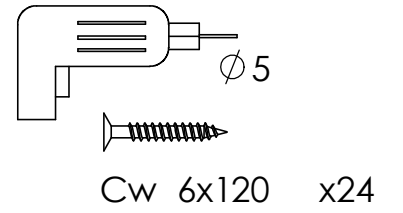
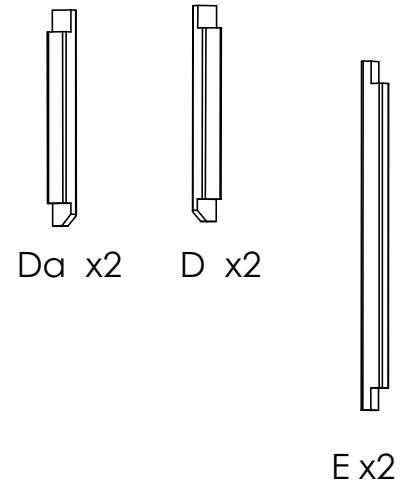
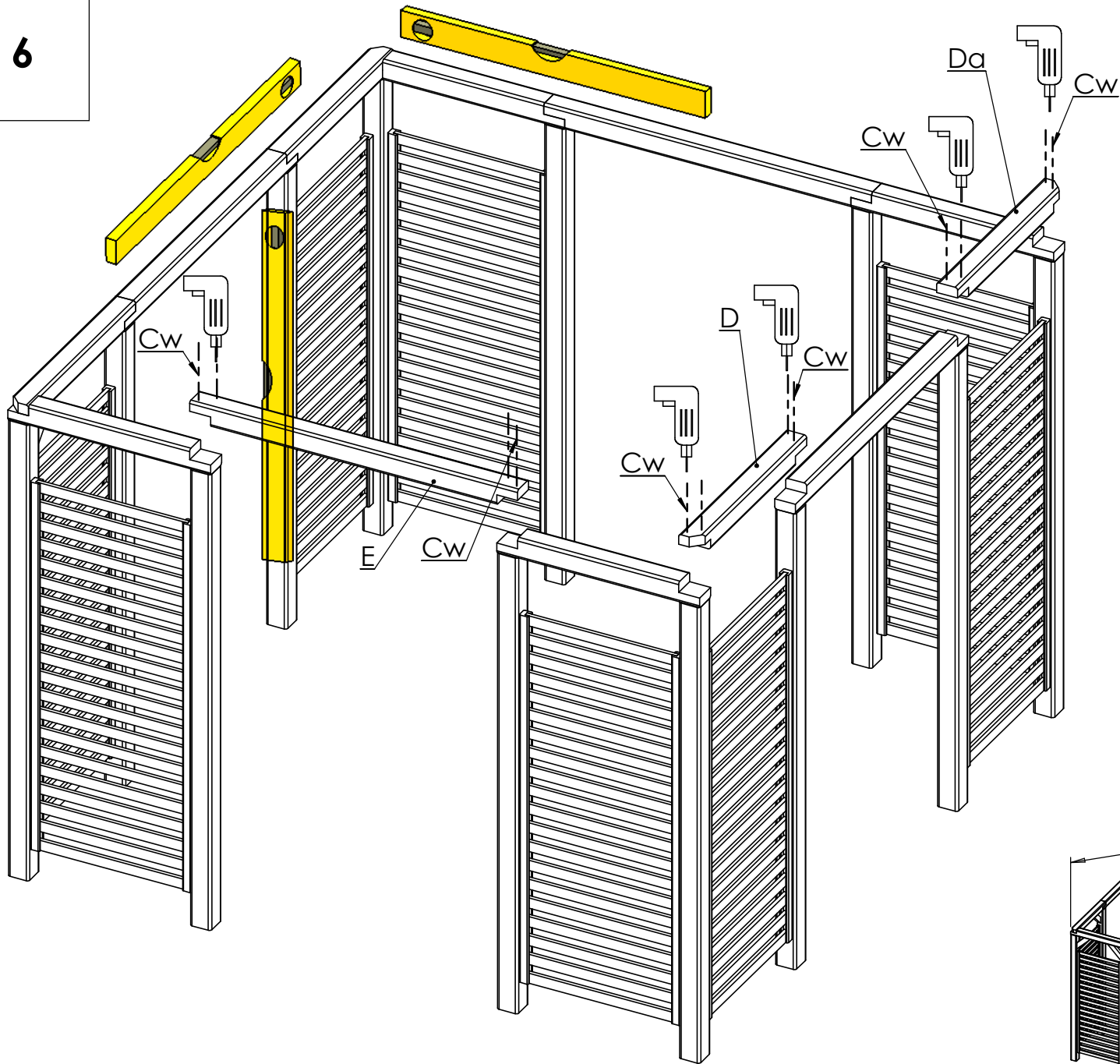

X = Y

7

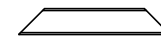
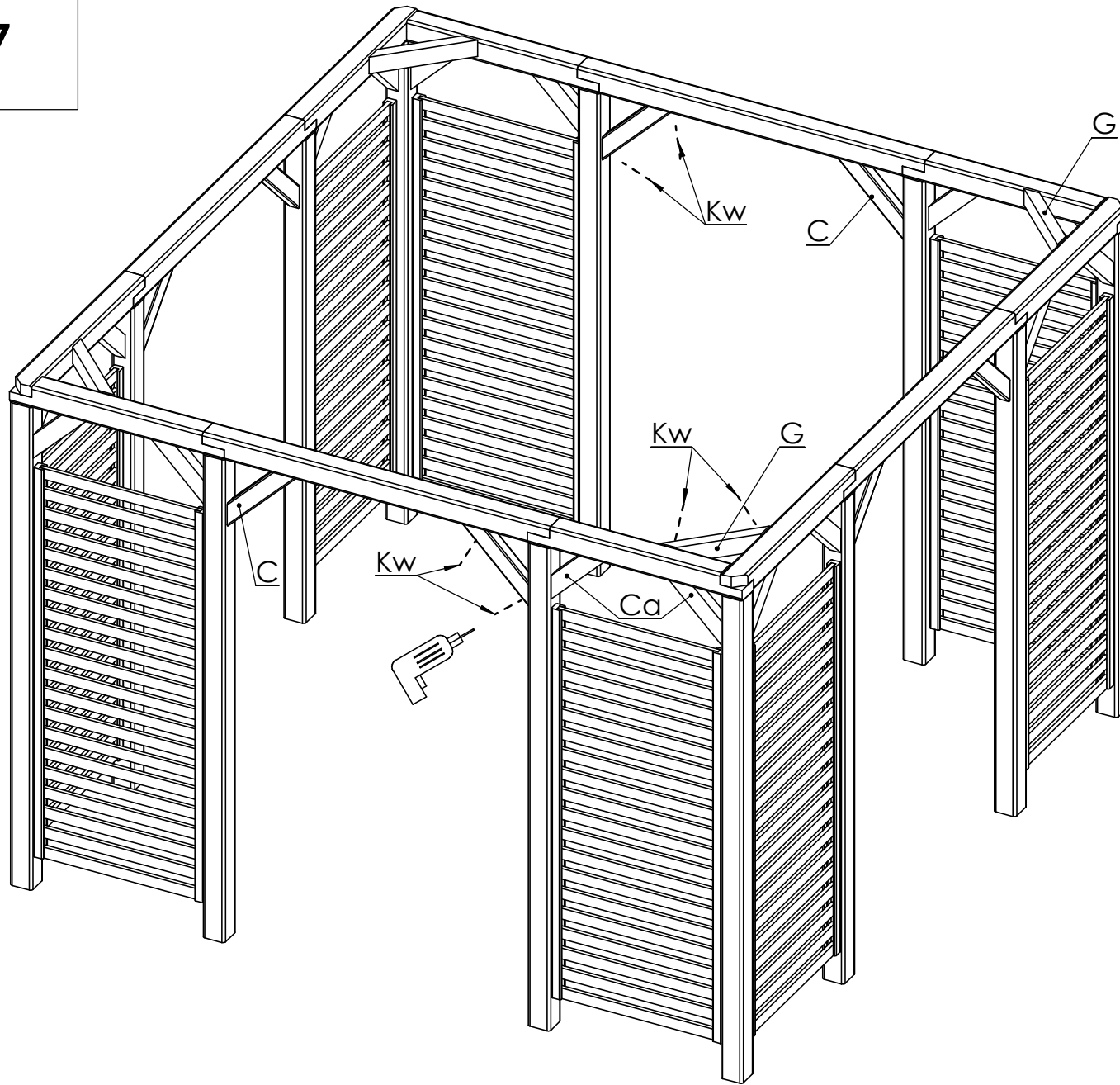

C x8

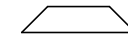

Ca x16

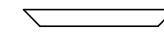

G x4

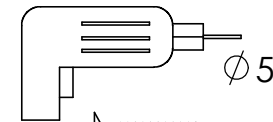

Ø 5

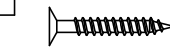

Kw 5x90 x56

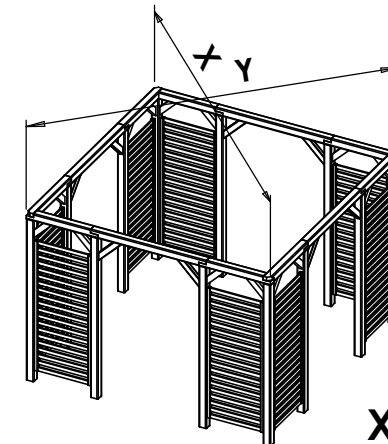

X = Y

8

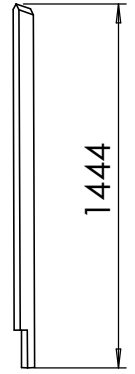
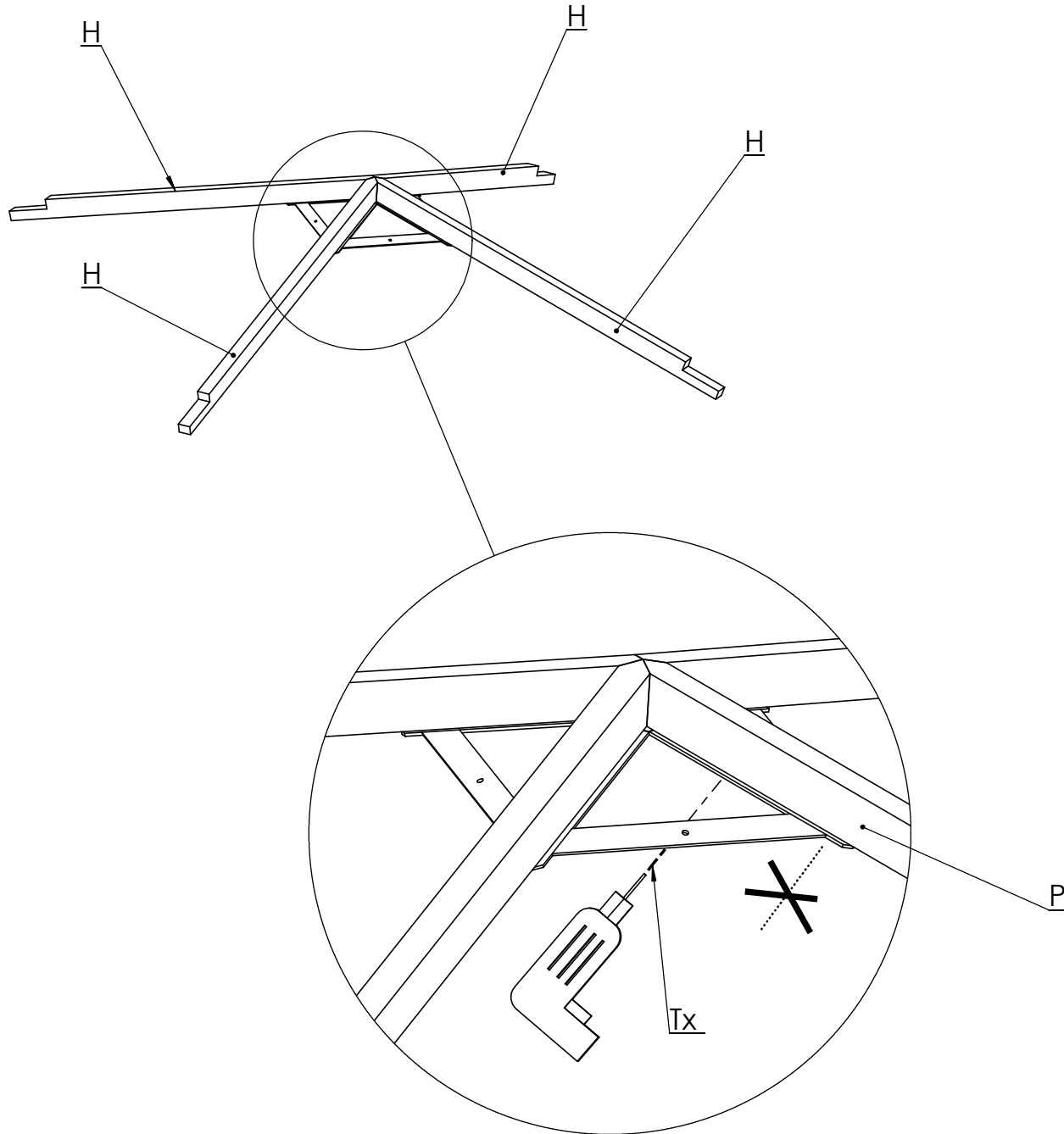

H x4

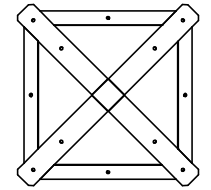

P x1

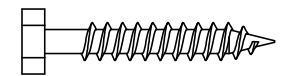
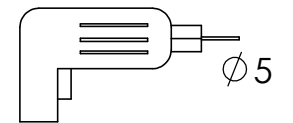

Tx 8x60 x4

9

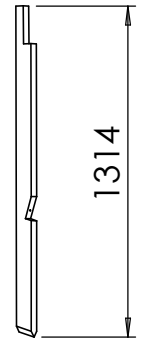
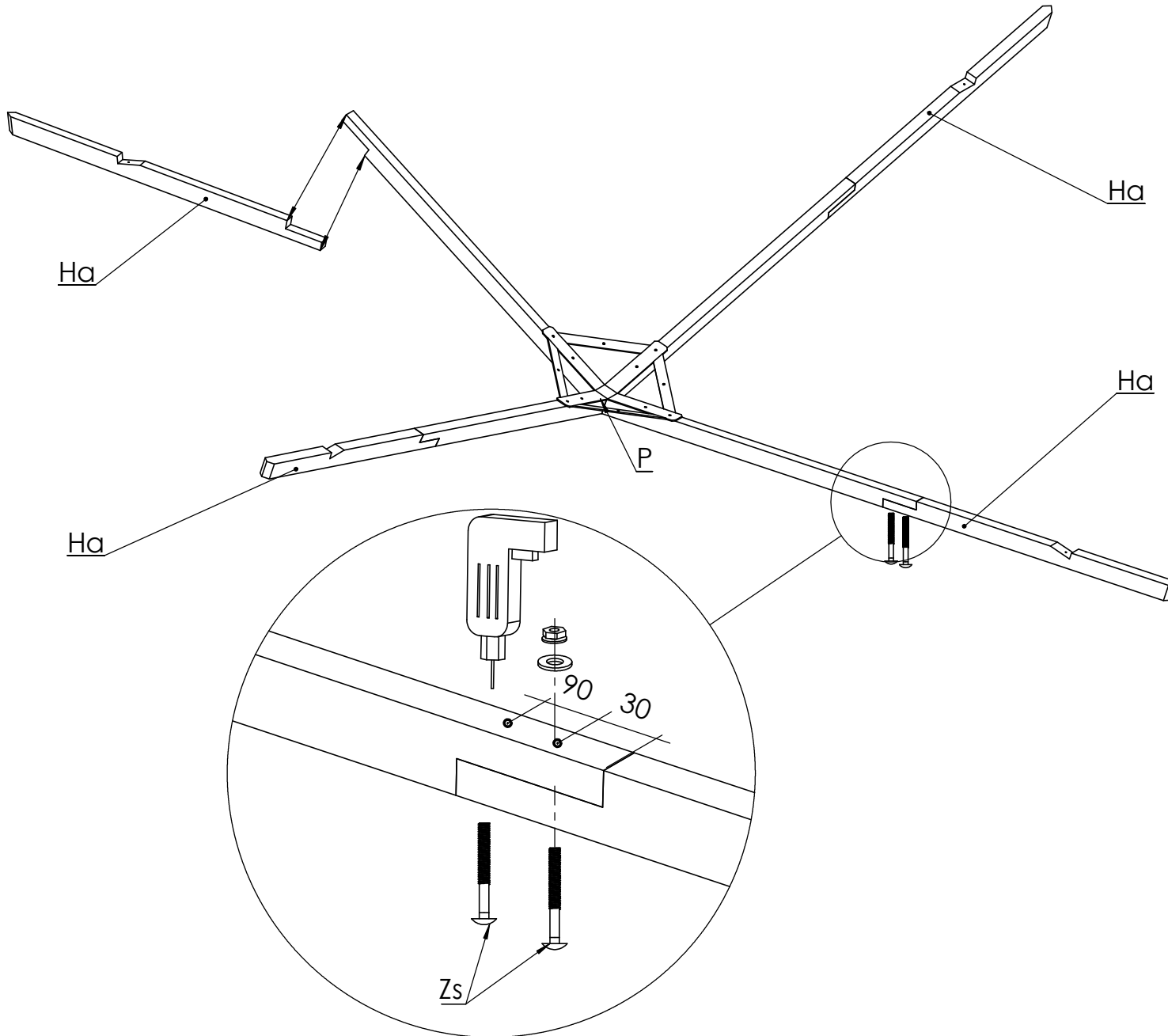

Ha x4

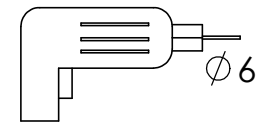
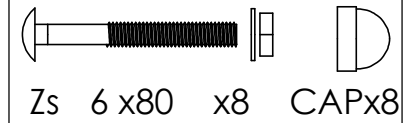

10

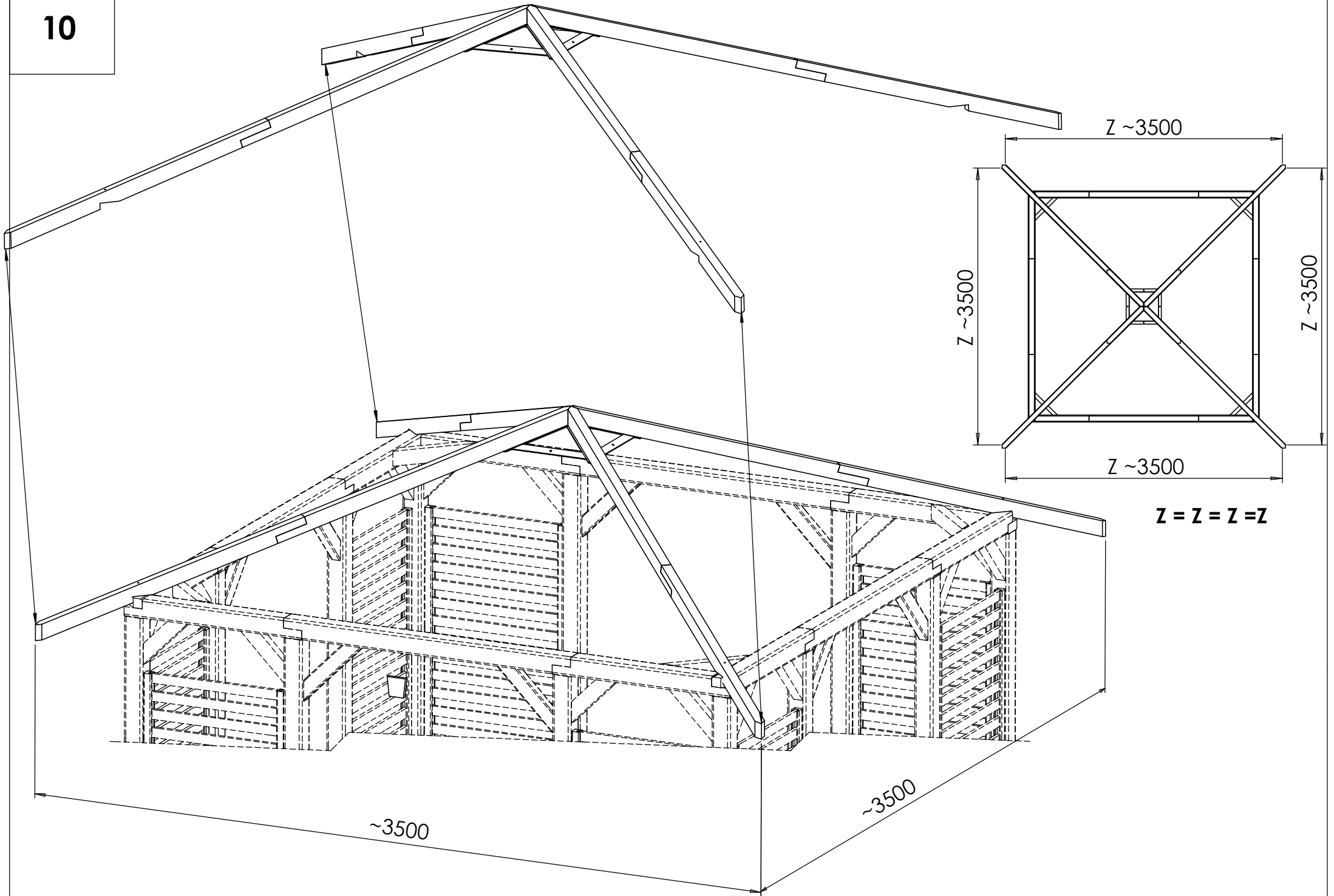

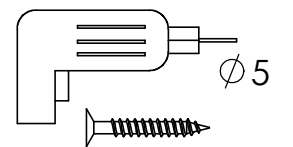
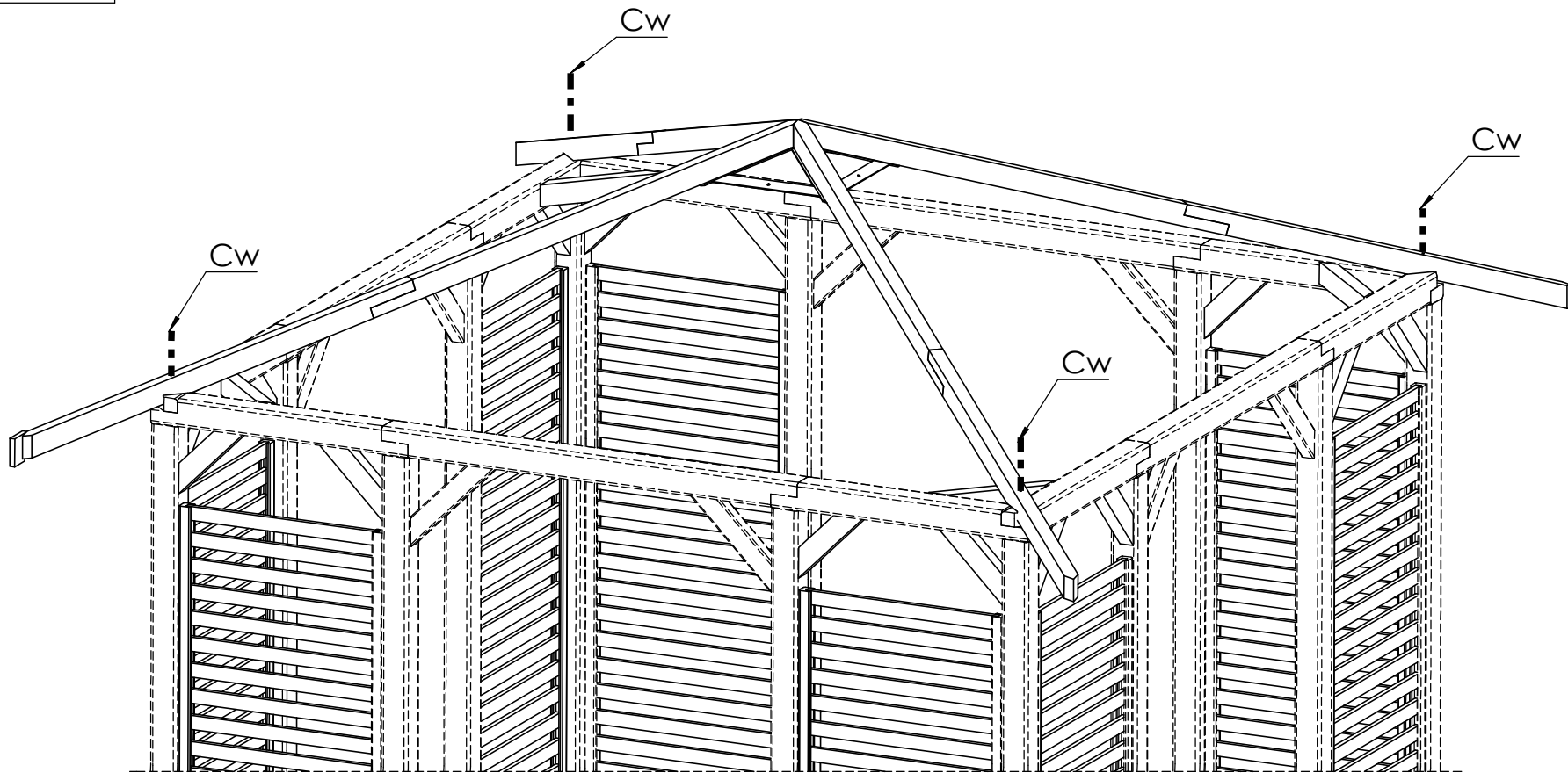

Cw 6x120 x4

12

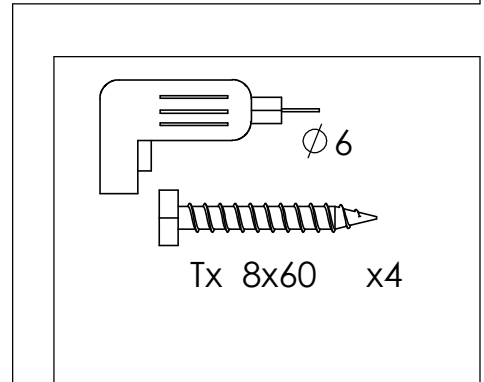
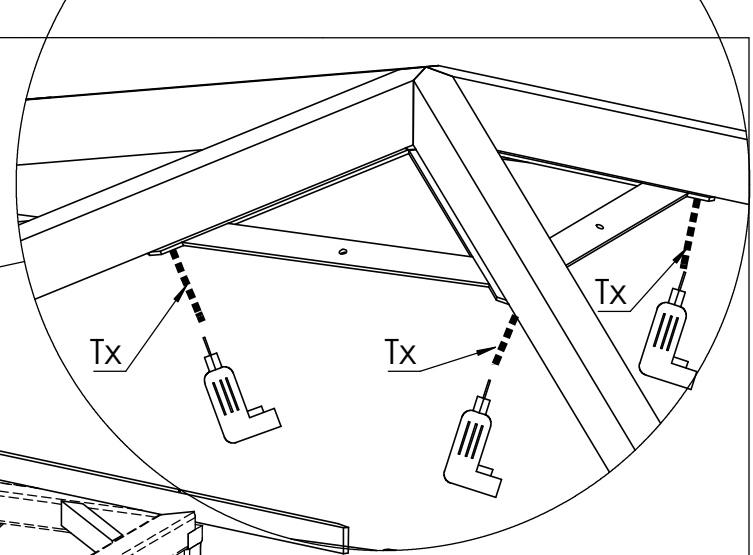
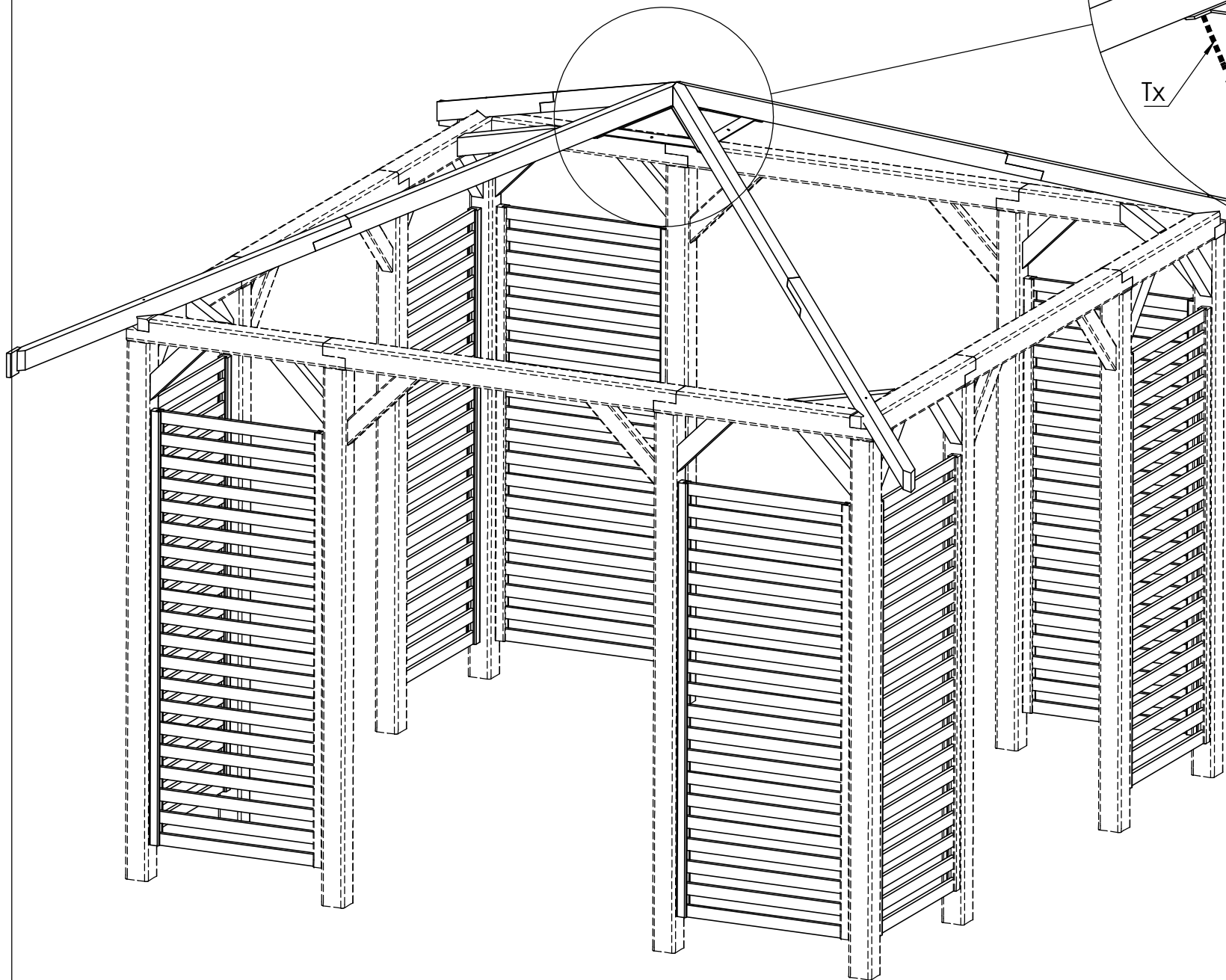

15

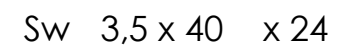
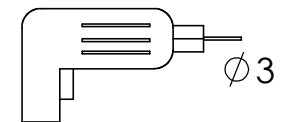
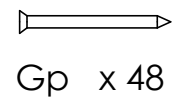
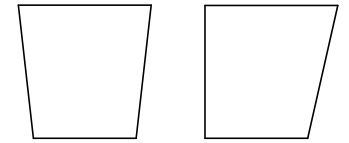
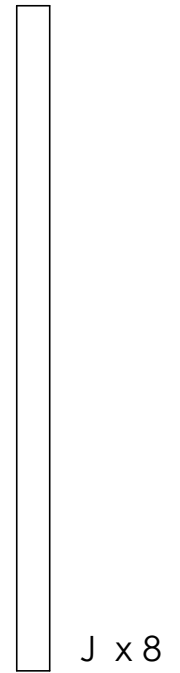
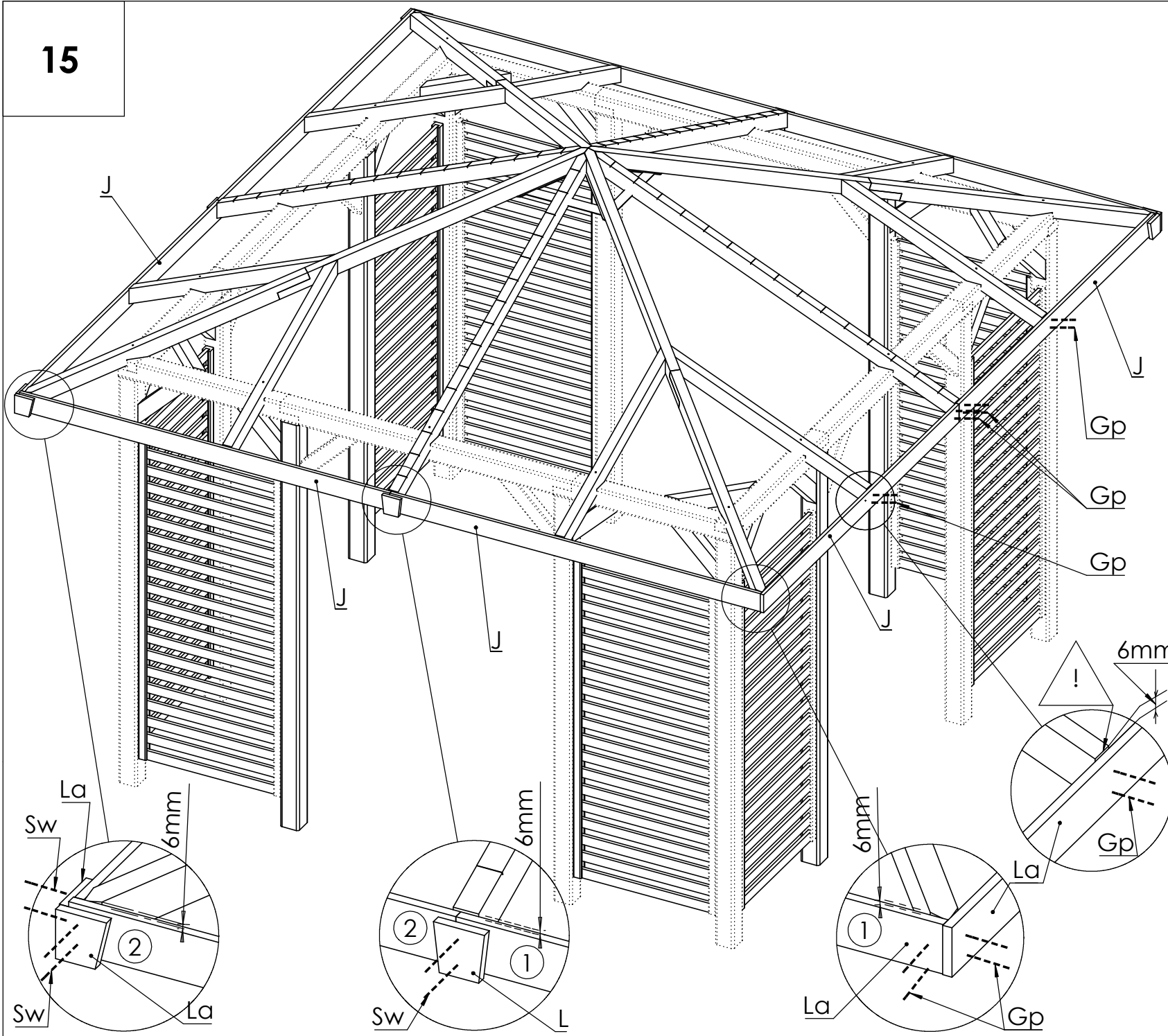

16

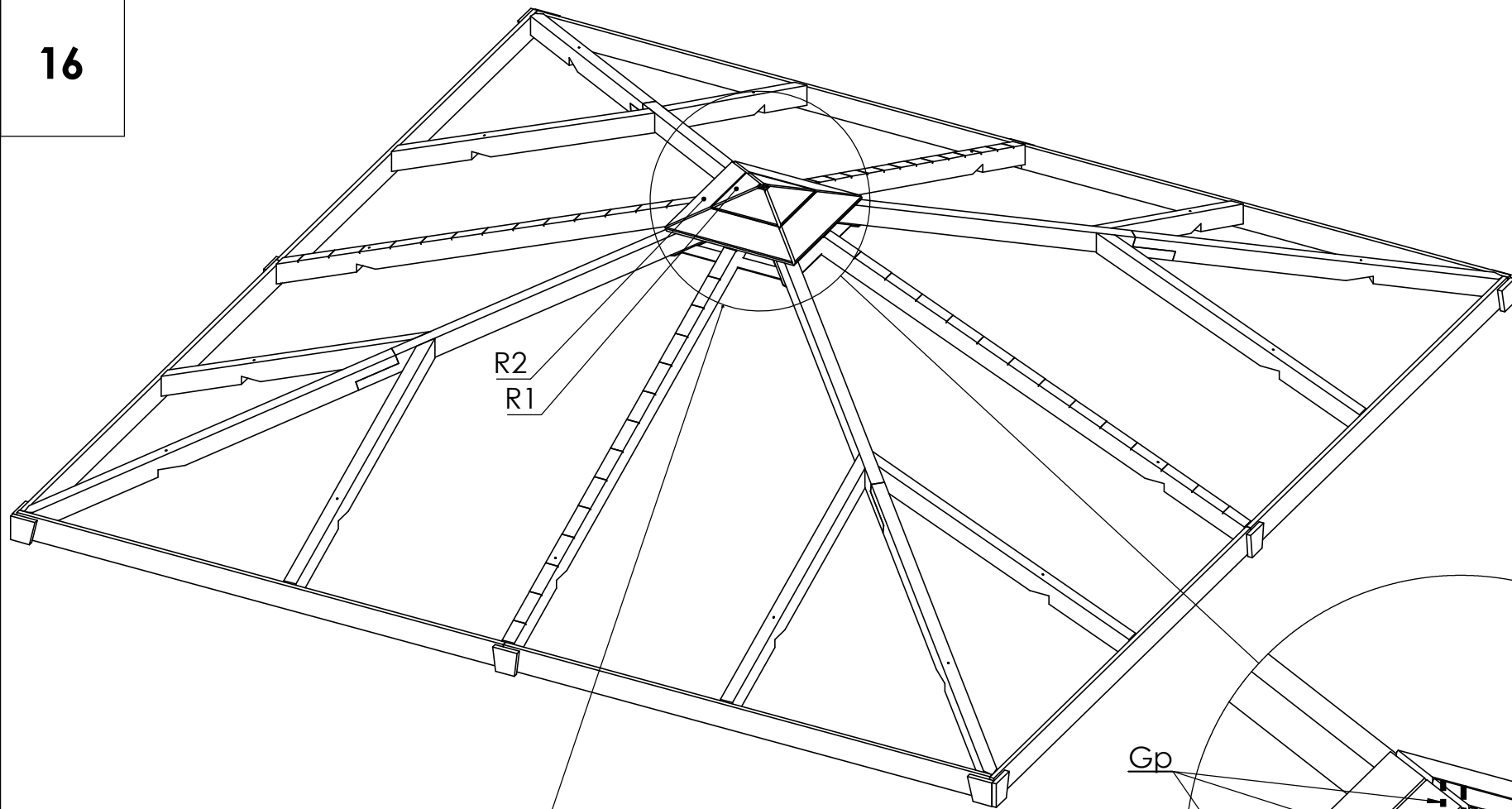

R2
R1

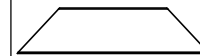

R(R1-R2) x8

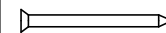

Gp x 36

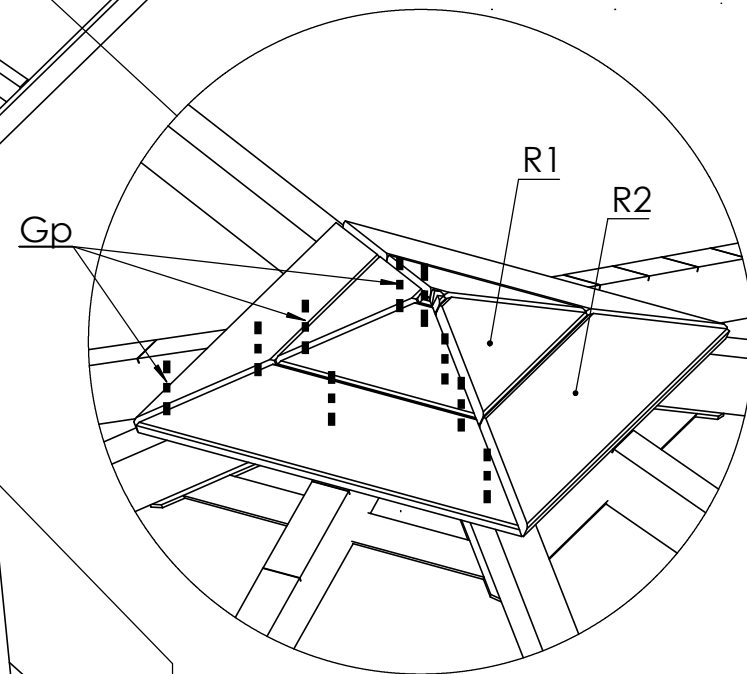

Gp

R1

R2

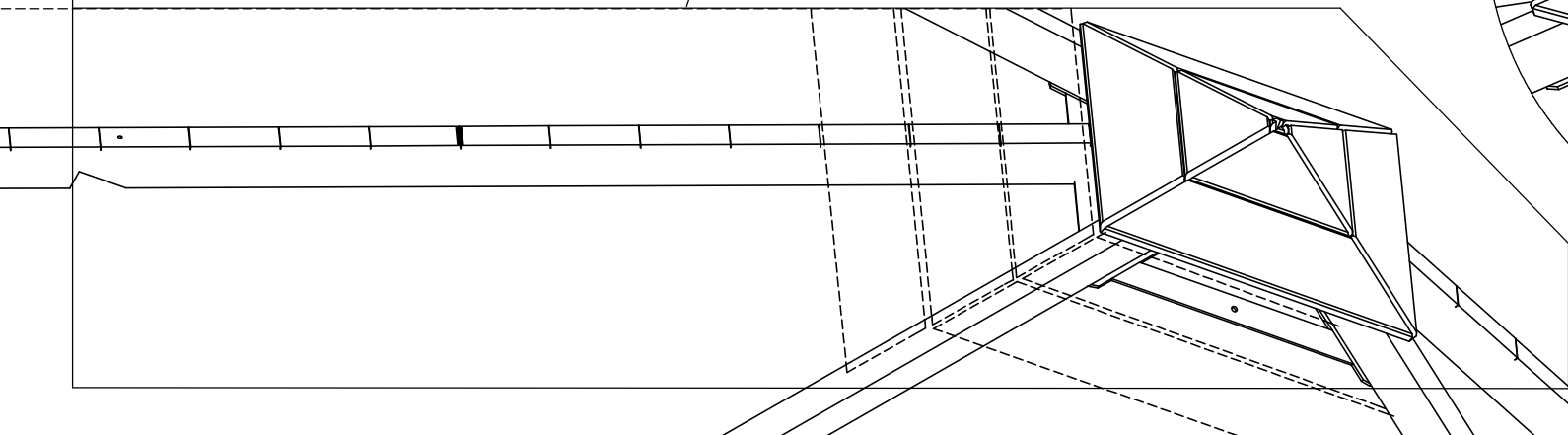

17

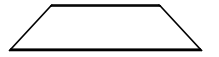
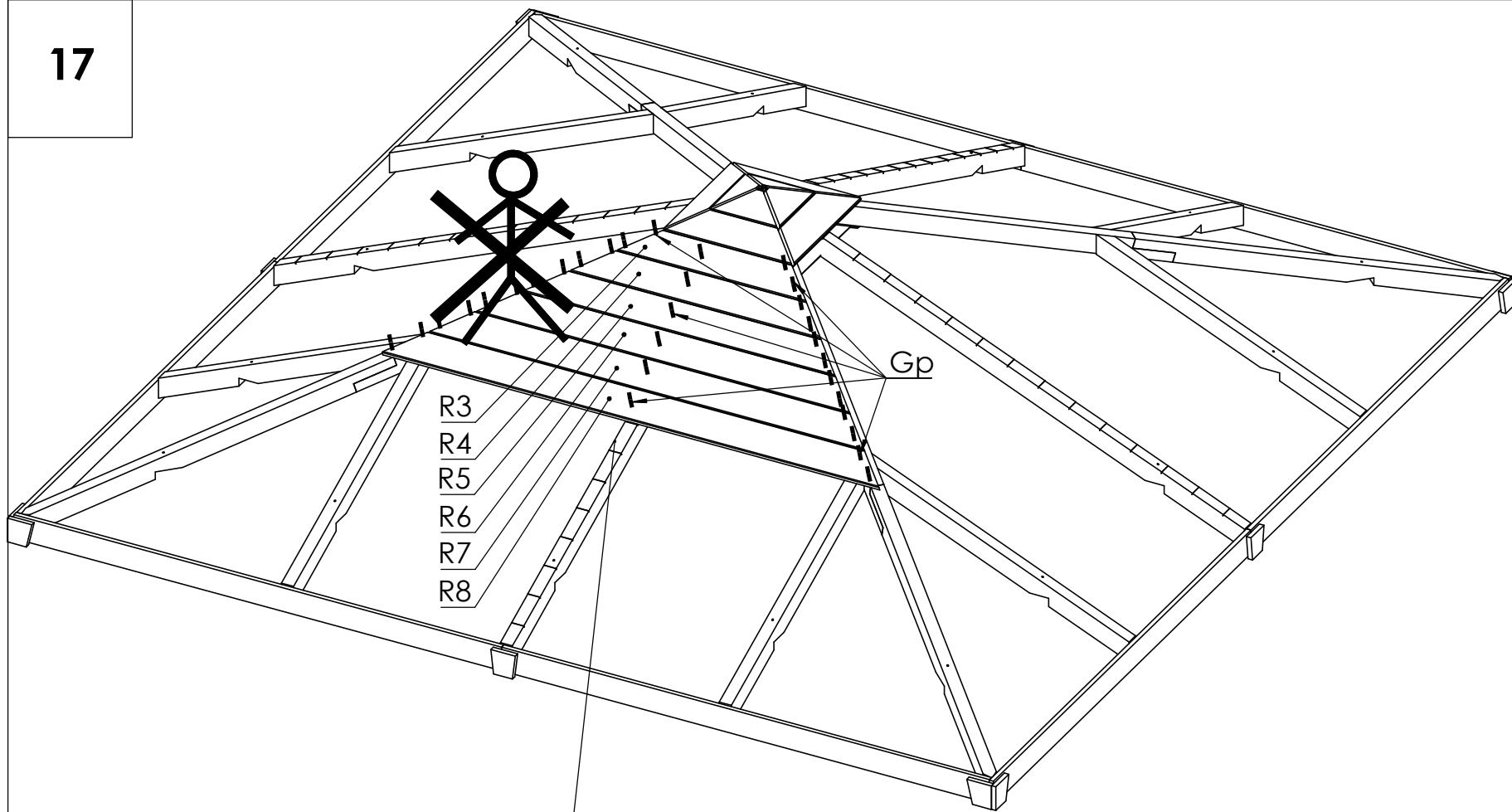

R(R3-R8) x6

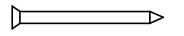

Gp x 30

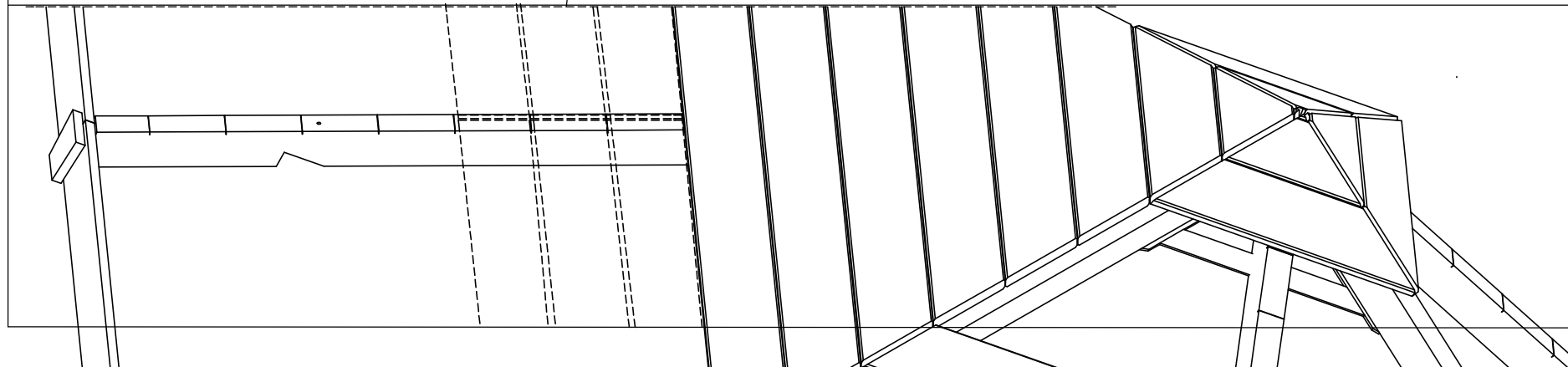

18

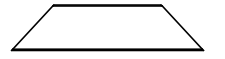
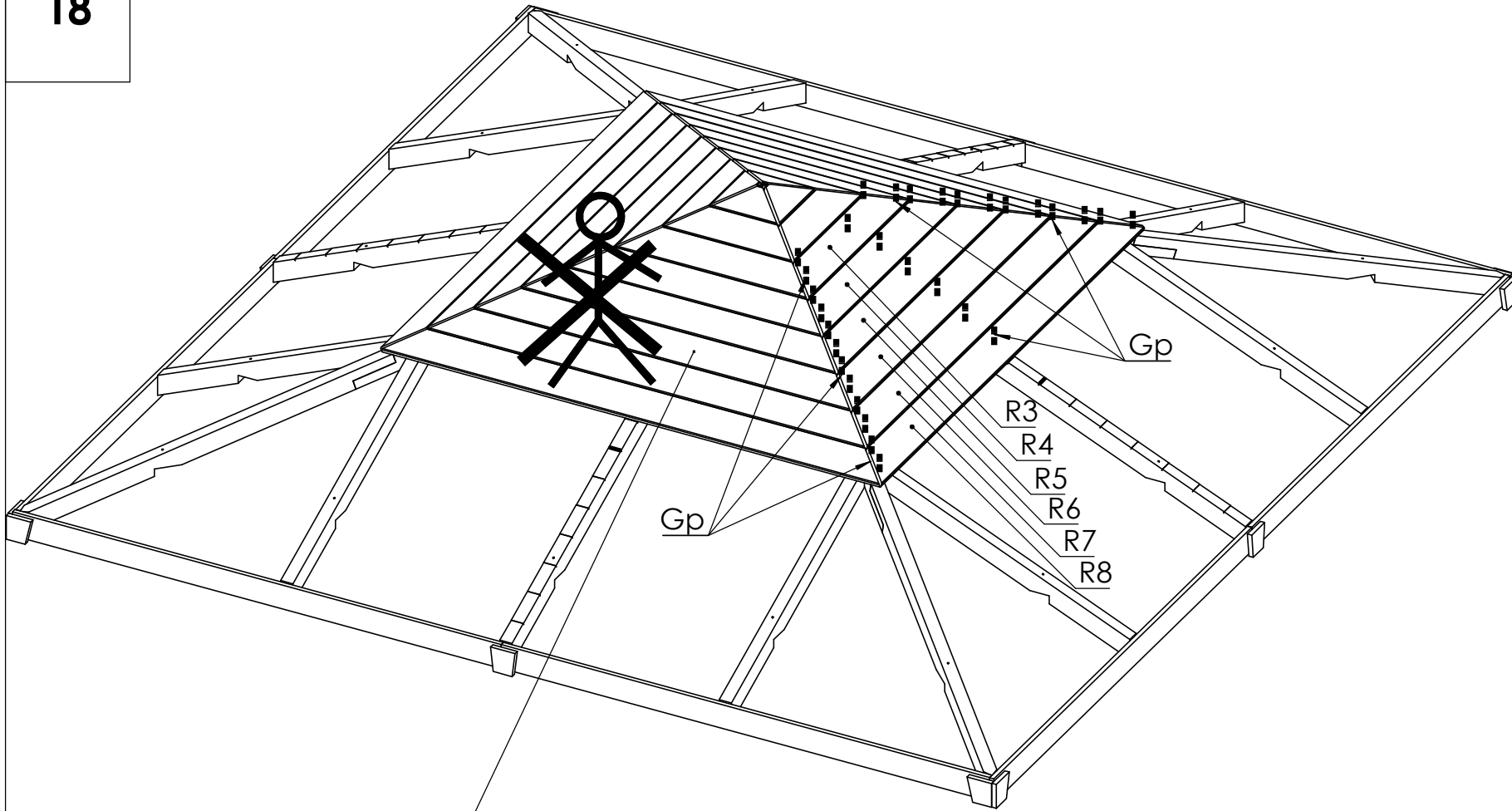

R(R3-R8) x18

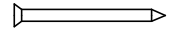

Gp x 90

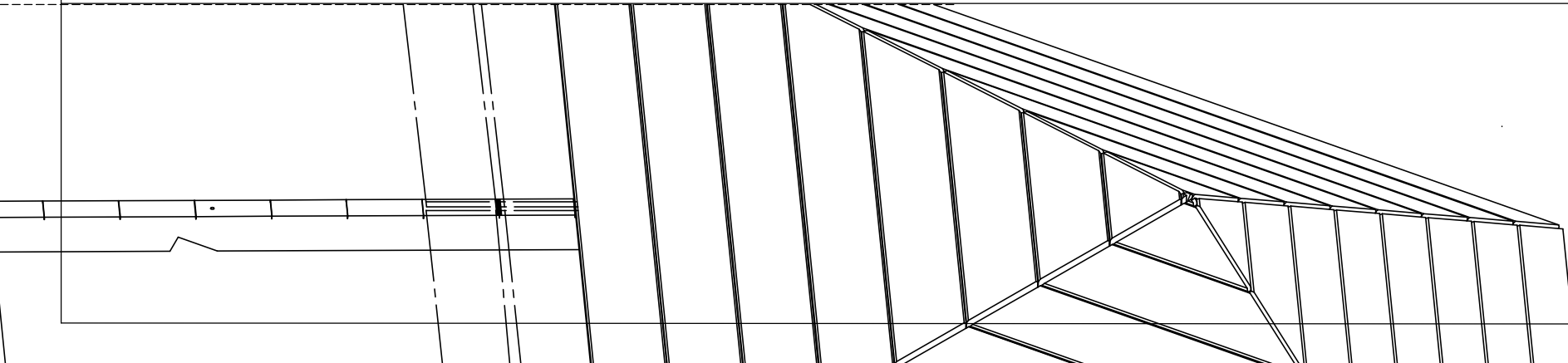

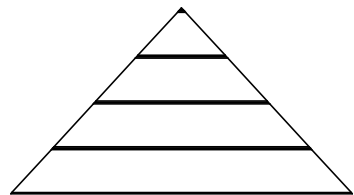
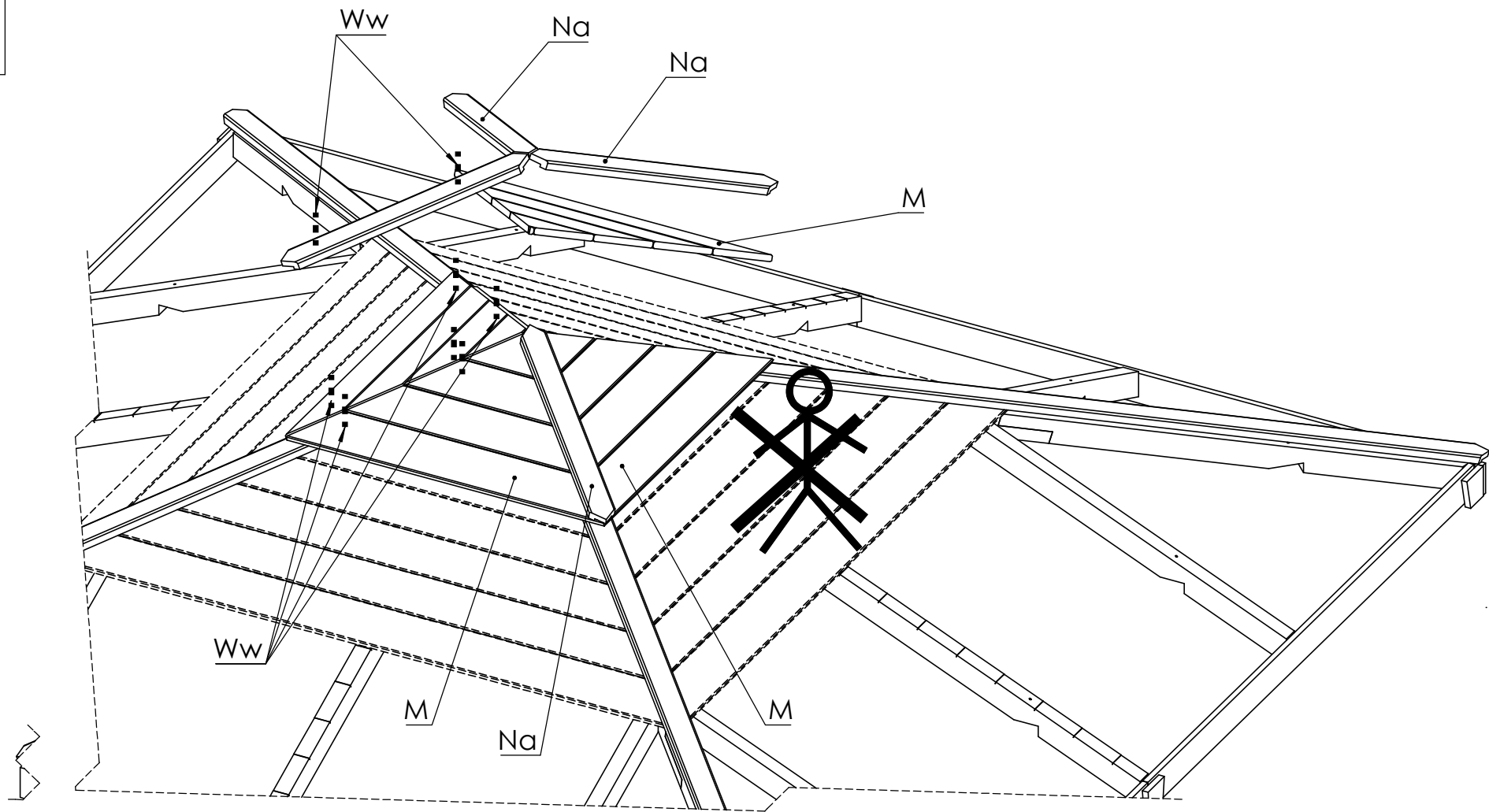

M x 4

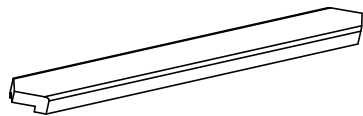

Na x 4

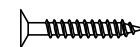
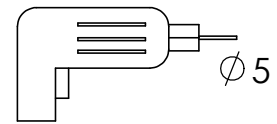

Ww 4x 70 x 24



T(T1-T8) x16

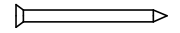

Gp x 80

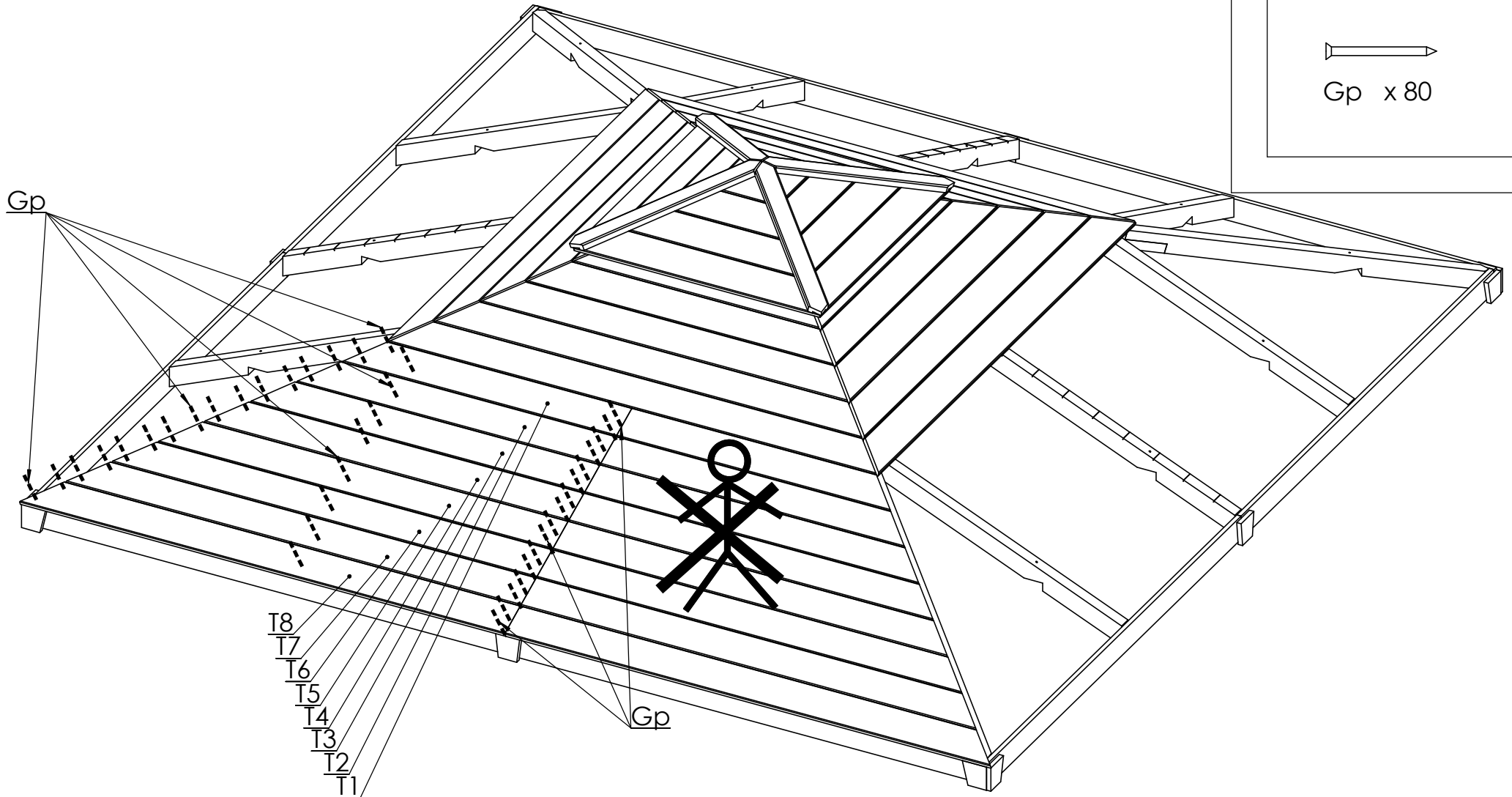

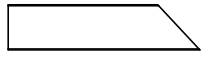

T(T1-T8) x48

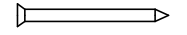

Gp x240

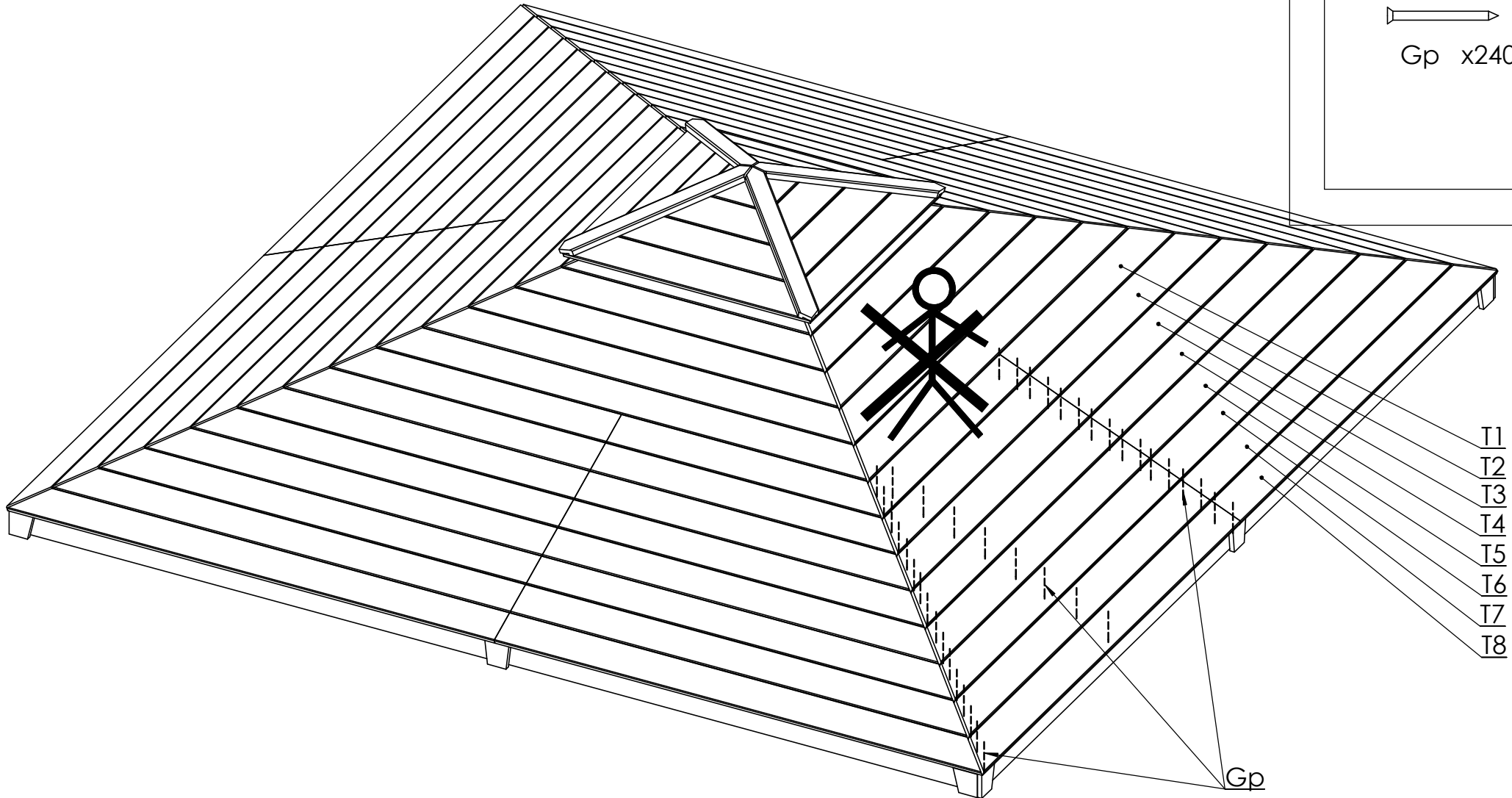

T1
T2
T3
T4
T5
T6
T7
T8

Gp

21

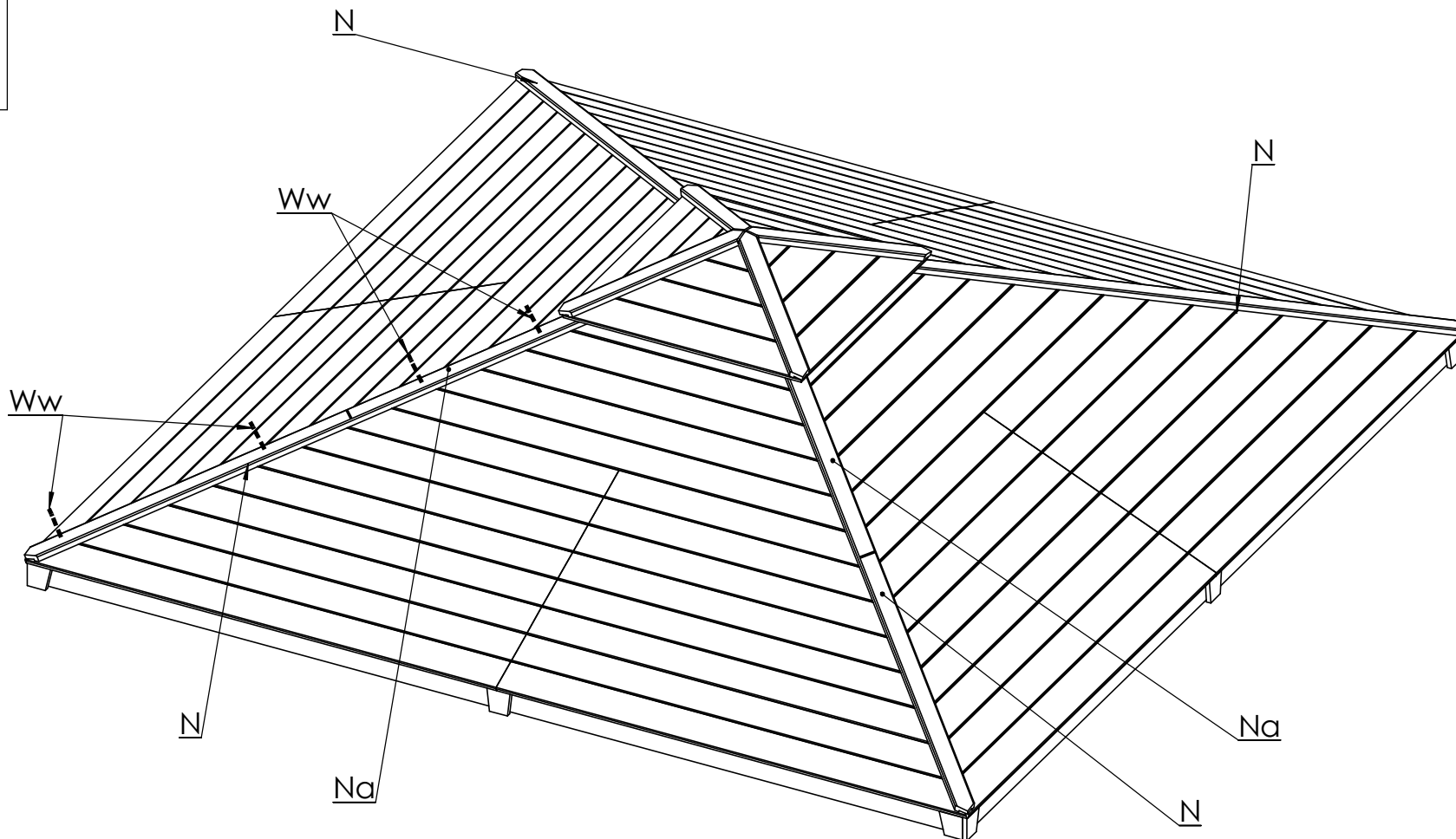

N x 4

Na x 4

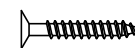

Ww 4 x70 x16

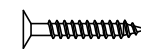
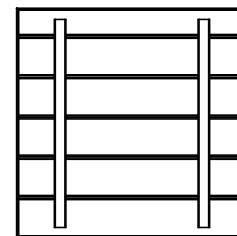
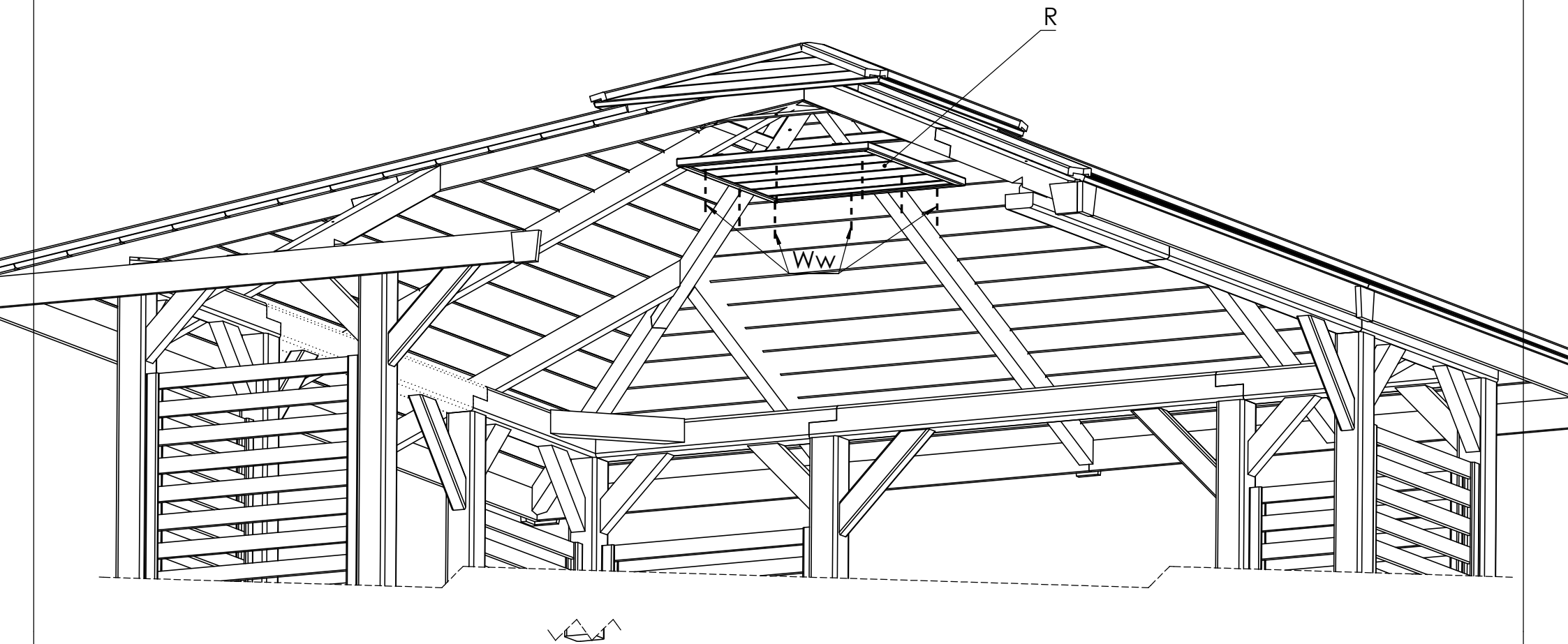

Ww 4 x70 x8

